



FITTING INSTRUCTIONS FOR

# Large Side Molle Panels

SKU

**KS0647**

COMPATIBILITY

**Nissan Patrol Y62**

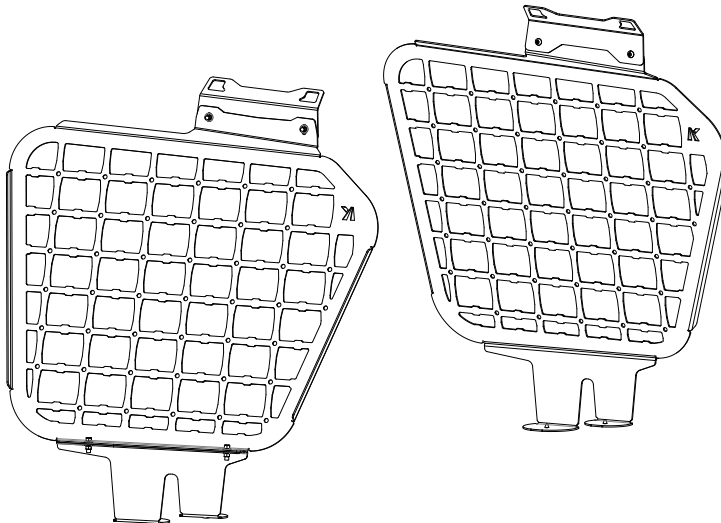

## Included contents

QTY	COMPONENT	QTY	COMPONENT
2	Large Side Molle Panels (LHS & RHS)	4	M6 x 16 Flanged Hex Bolt G8.8
2	Handle Brackets	8	M6 Flanged Nut
2	Feet Brackets (LHS & RHS)	4	M6 x 12 Button Head Socket Screw



**Time**

30 minutes / Half a beer

Scan the **QR code** to watch the video installation guide,  
or for further information contact KAON on **07 3180 1470** or [info@kaon.com.au](mailto:info@kaon.com.au)



# Let's get to work.

## Assembling the Large Molle Panel

1. Ensure you have the correct foot for each Molle Panel before assembling. To check you have the correct corresponding Molle Panel, confirm that the foot profile match the base of the panel, and that the holes align.
2. Attach each foot to it's Molle Panel, using the provided M6 bolts and nuts.
3. Tighten all bolts to secure.

### If you're installing the Molles on their own or with a Light Cargo Barrier:

4. Loosely attach the provided handle bracket to the Molle Panel using the M6 bolts. The handle bracket should fold forward, in the same direction as the Molle Panel feet.

### If you're installing with a Standalone Shelf:

5. Set the handle bracket included with the Molle Panels to one side for safe keeping. A replacement handle bracket is included with the shelf.



## Preparing the Vehicle

6. Pry open the plastic covers on the rear grab handles with a small flatblade screwdriver or trim tool.
7. Use a 10mm socket to remove the rear handles. Set aside.



## Installing the Molle Panel

8. Ensure you have the correct panel for each side. The 'K' should be positioned at the back of the vehicle. If you're intending on mounting anything to the Molle Panel, it's easiest to do it now.
9. Place the feet of the Molle Panel into the rear cupholders. The feet are contoured to fit, and the rubber stoppers will keep it secure.
10. Align the handles with the cutouts in the brackets. Align the bolts and locating pins with the holes in the roof, and reinstall by tightening to secure.
11. Make any necessary adjustments to the panel. While applying downwards pressure to the panel, tighten all bolts.
12. Repeat on the other side.
13. That's it, you're done!

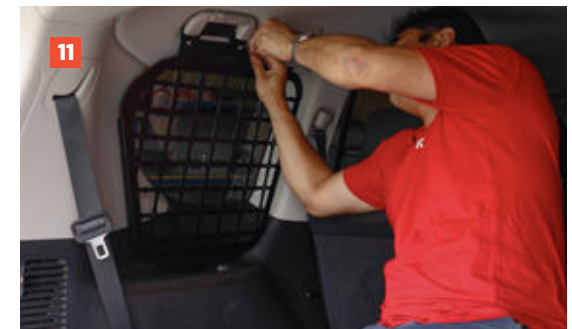

THIS PAGE INTENTIONALLY LEFT BLANK.

THIS PAGE INTENTIONALLY LEFT BLANK.

## Bolt Torque

<b>DIAMETER (mm)</b>	5mm	6mm	8mm	10mm	12mm
<b>NEWTON-METRES (Nm)</b>	5 Nm	9 Nm	22 Nm	44 Nm	77 Nm



### Local Knowledge & Assistance

We know half the fun of building your dream 4x4 is getting your hands dirty. But we also know that sometimes, things don't go to plan. If in the pursuit to build the ultimate setup you find yourself off-track, we're here to help you get unstuck.

For further information call 07 3180 1470 or email [info@kaon.com.au](mailto:info@kaon.com.au)

Disclaimer: The products sold by KAON should not be modified, and are for use only on the vehicles specifically stated. KAON will not be liable for any damages arising out of the use or misuse of its products. It is the customers responsibility to ensure the products are safely and properly used and installed. KAON consistently seeks to improve its products and reserves the right to make changes to any product.